

INDEX

---

Introductory .....	2
Illustrations .....	3
To Unpack .....	4
The Marginal Stops.....	4
Insertion of Paper .....	4
Writing-Line .....	5
Paper Release Key .....	5
Beginning a New Line.....	6
Regulating Space between Lines.....	6
Regulating Space between Words.....	6
The Carriage Release Keys.....	6
The Capital Shift Key.....	7
Writing on Ruled Lines.....	8
Right Marginal Release Key.....	8
Left Marginal Release Key.....	9
Automatic Ribbon Reverse.....	9
Bichrome Device .....	10
Changing Ribbons .....	10
New Ribbons .....	11
Tabular Key .....	11
Tabular Stops .....	12
Back Space Key .....	12
The Centering Scale, Plate 8.....	12
Making Corrections .....	13
The Envelope Guide.....	14
Varying Widths of Paper.....	14
Stencil Cutting .....	14
Cleaning Machine .....	14
Cleaning the Type .....	15
Oiling .....	15
What Not to Do.....	15

# Instructions for Using The Underwood Typewriter

---

## Models 3, 4 and 5

---

The object of this book is to give plain and simple directions for the operation of the mechanical features of the Underwood Typewriter.

First, it is not intended to give information that will enable the operator to take the machine apart.

Taking a typewriter apart by one inexperienced is the greatest possible detriment to the machine.

It is most important that the machine be kept clean.

It is necessary that the machine be oiled only as required—the back way rod (Plate 1, Fig. 1, and Plate 3, Fig. 1) daily. Too much oil, however, is as injurious as too little.



## ILLUSTRATIONS

As an aid to a quick and thorough understanding of the Instructions for Using the Underwood Typewriter, three full views of the machine are given, with five additional illustrations of portions of the machine not clearly visible in the general views.

	<i>Page</i>
Plate 1. A side view of the machine.....	3
Plate 2. A front view of the machine.....	5
Plate 3. A rear view of the machine.....	7
Plate 4. The Line Spacing Mechanism.....	8
Illustrating Change of Ribbons.....	9, 10
Plate 7. Showing the End of the Ribbon.....	11
Plate 8. Showing Centering Scale.....	13

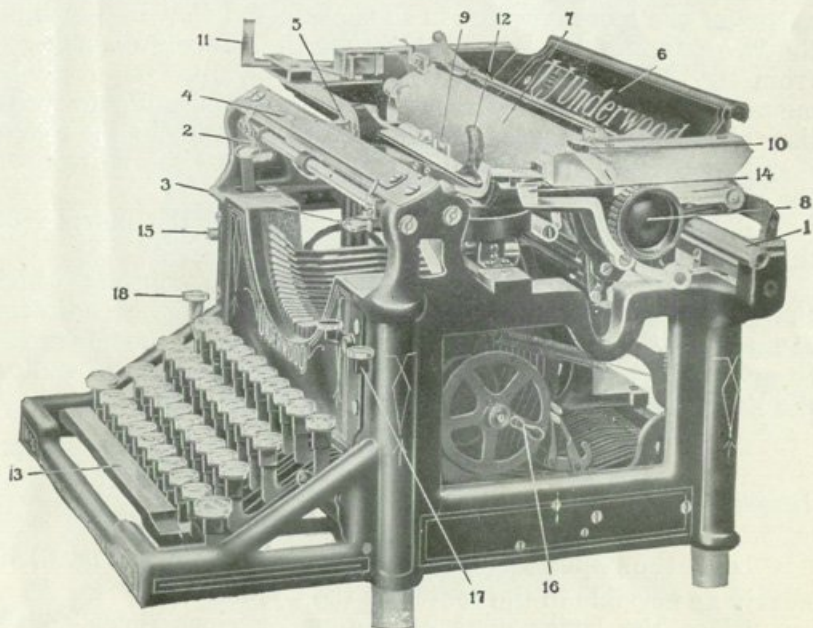

PLATE 1

*To Unpack.*

Remove the screws from around the edge of the bottom of the case. Lift the bottom of the case, to which the machine is attached, from the case. Then take out the four bolts which hold the machine; after which remove the iron skids; the rubber feet, which will be found in a small package under the rubber cover, should then be screwed to the machine.

Cut the tape holding the Carriage, Locking Device, Back Spacer and Carriage Release.

*The Marginal Stops.*

The Marginal Stops (Plate 1, Figs. 2 and 3, Plate 2, Figs. 1 and 2) are in front in the most natural and convenient position. When the machine is unpacked they will be found pushed to the center of the Scale (Plate 1, Fig. 4).

These Stops can be moved to any desired position by means of the handle, which is so constructed that by pinching the two parts of the handle together the Stop is disengaged from the rack which holds it in position, allowing it to be moved freely in either direction. Before beginning to write they should be separated and pushed to the ends of the Scale.

The Right-hand Marginal Stop regulates the margin on the left side of the paper.

The Left-hand Marginal Stop regulates the margin on the right side of the paper.

The bell will ring six spaces before the point at which the Left-hand Marginal Stop is set, and when the Indicator (Plate 1, Fig. 5, and Plate 2, Fig. 3) reaches the Marginal Stop (Plate 1, Fig. 2), the Type-bars will lock, thus ending the line positively without piling letters.

*Insertion of Paper.*

Drop the paper upon the Paper-rest (Plate 1, Fig. 6) as nearly as possible in the center of the Cylinder.

Place the lower edge of the paper close down to the Cylinder (Plate 1, Fig. 7) and turn the Cylinder from you



by either one of the Cylinder Knobs (Plate 1, Fig. 8, and Plate 2, Fig. 4) until the position of the paper upon which you desire to write has been reached.

*Writing Line.*

The writing position upon the paper is determined by sight. The line of writing is just above and parallel with the Cylinder Scale (Plate 1, Fig. 9, Plate 5, Figs. 1 and 2).

Each impression is made directly behind the notch in the Type Guide (Plate 5, Fig. 3) through which each Type-bar passes on its way to the Cylinder.

*The Paper Release Key.*

By depressing the Paper Release Key (Plate 1, Fig. 10, Plate 2, Fig. 5) the pressure will be relieved from the Feed Rolls, thus allowing the free use of both hands for the adjust-

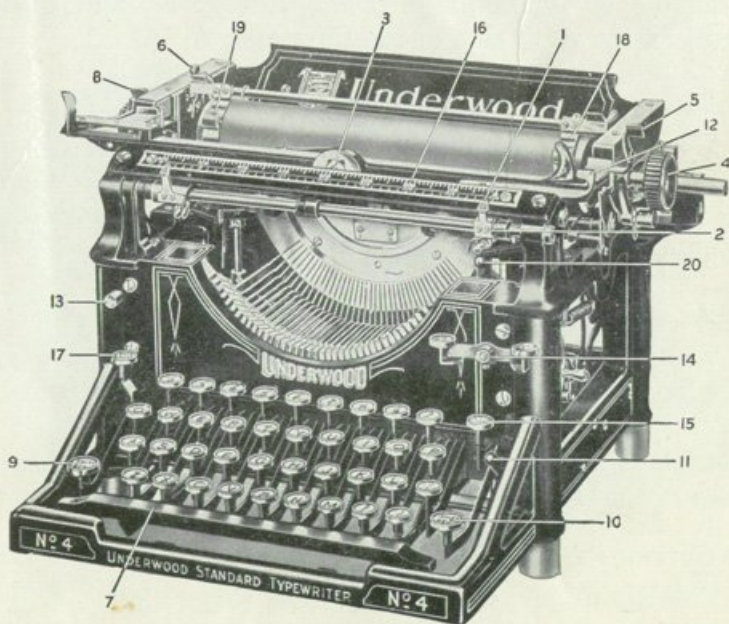

PLATE 2

ment of the paper. When the paper is adjusted always return the Release Key to its normal position before writing. If it is desired simply to relieve the pressure from the paper for a minor adjustment this can be done by resting the side of the right hand on the Paper Release Key. When the hand is removed the key will spring back and the Feed Rolls will again engage the paper.

#### *Beginning a New Line.*

To begin a new line, push the Carriage to the right as far as it will go, by the Line Space Lever (Plate 1, Fig. 11, and Plate 4, Fig. 1) which is on the left side of the Carriage in front.

The space between lines is made automatically when the Carriage is returned by the Line Space Lever. If it is not desired to change the line when returning the Carriage use the handle or thumb-piece (Plate 1, Fig. 12, and Plate 3, Fig. 2) on the right side of the Carriage.

#### *Regulating Space Between Lines.*

When the Line Space Adjusting Lever (Plate 2, Fig. 6, and Plate 4, Fig. 2) is set at 1 on the plate, the use of the Line Space Lever will automatically make a single space; if at 2 a double space, and at 3, three spaces.

#### *Regulating Space Between Words.*

The Space Bar (Plate 1, Fig. 13, and Plate 2, Fig. 7) is the long bar extending across the front of the keyboard.

The Space Bar is depressed once after each word and punctuation mark except at the end of a sentence, when two spaces are made.

#### *The Carriage Release Keys.*

The Right-hand Carriage Release Key (Plate 1, Fig. 14) extends from the upper right side of the Carriage in front of the Cylinder Knob, in the most convenient position.



To move the Carriage to the left, place the right thumb against the handle or thumb-piece (Plate 1, Fig. 12, and Plate 3, Fig. 2) on the right side of the Carriage, and depress the Carriage Release Key with one of the fingers of the right hand.

The Left-hand Carriage Release Key (Plate 2, Fig. 8, Plate 3, Fig. 3, and Plate 4, Fig. 4), extends from the upper left-hand side of the Carriage in front of the Cylinder Knob. To move the Carriage to the left, depress this key with the index finger of the left hand, holding the Carriage steady with the thumb and second finger.

*The Capital Shift Key.*

The Shift Keys on either side (Plate 2, Figs. 9 and 10) are for use in making Capitals. When a Capital is required depress either of the Shift Keys, releasing them immediately after the letter has been printed.

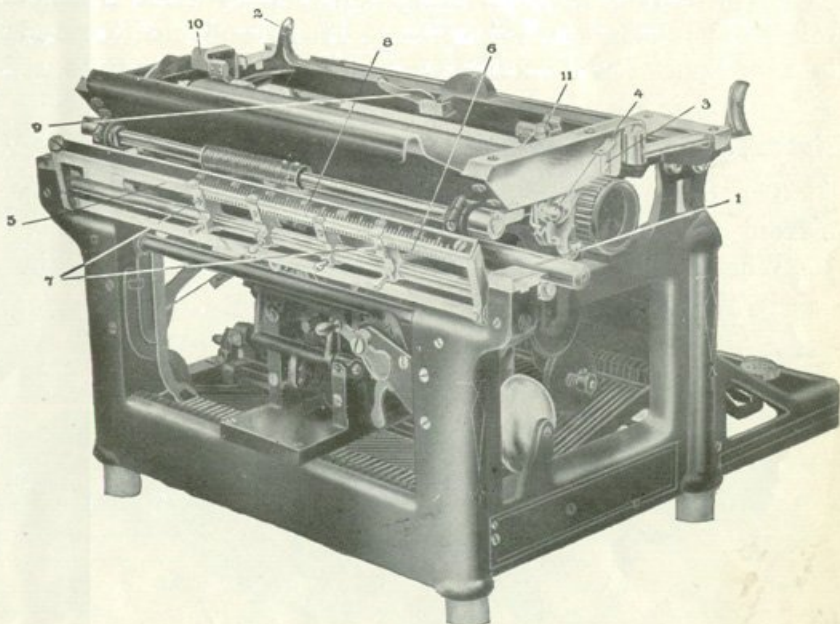

PLATE 3

If it is desired to write a whole sentence in Capitals depress the Shift Key Lock (Plate 2, Fig. 11) after which depress the Right Shift Key. To return to lower case letters touch either the Left Shift Key or the Shift Key Lock.

In touch typewriting, where both shift keys are required for writing Capitals, the Shift Key Lock should be kept up in its normal position, when either Shift Key may be used for a single Capital.

#### *Writing on Ruled Lines.*

To write on ruled lines pull the Cylinder Ratchet Release, back of the Left-hand Cylinder Knob (Plate 3, Fig. 4, and Plate 4, Fig. 3) up as far as it will come and turn the paper to the desired position by means of either of the Cylinder Knobs. The lines, you will understand, should be just even with the top of the Cylinder Scale.

When regular work is being done the Cylinder Ratchet Release should be pushed down to its normal position and the Line Space Lever used for turning the regulation lines.

#### *Right Marginal Release Key.*

The Right Marginal Release Key (Plate 2, Fig. 12) is in front of the extreme right of the Carriage.

When it is desired to write outside of the Margin on the

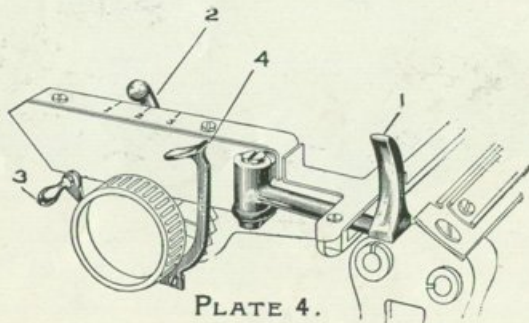

PLATE 4.



left side of the paper, depress the right-side Marginal Release Key, which will permit the free movement of the Carriage beyond the Marginal Stop.

*Left Marginal Release Key.*

The Left Marginal Release Key (Plate 1, Fig. 15, and Plate 2, Fig. 13) extends from the front of the main frame on the left side.

When it is desired to write additional characters beyond the Line-lock or Left Marginal Stop press this key (it is not necessary to hold it) which will unlock the keys and permit the writing of additional characters. When the keys lock again still another character may be written by pressing this Release Key a second time.

*Automatic Ribbon Reverse.*

The Ribbon Reverse is automatic, but may be reversed by hand by pushing the Ribbon Spool Ratchet Wheel (Plate 1, Fig. 16) either to the right or left, as the case may require.

The Ribbon may be wound on one Spool by means of the handle on the Ribbon Spool Ratchet Wheel. If you are winding from the right-hand Spool to the left, the wheel should be pressed to the left. If winding from the left-hand Spool to the right, the wheel must be held firmly to the right.

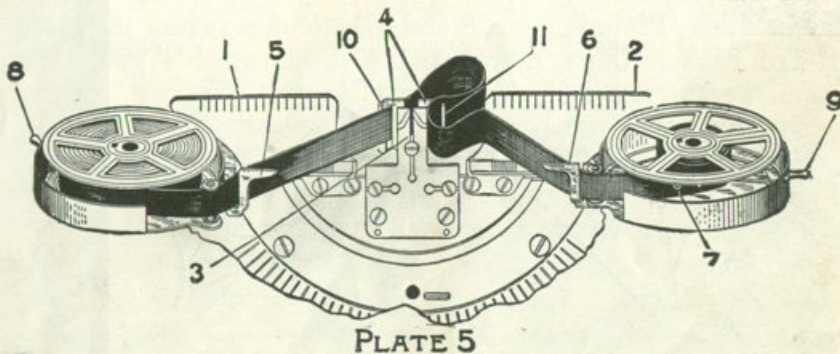

*Bichrome Device.*

The Shift-keys controlling the Bichrome Ribbon (Plate 1, Fig. 17, and Plate 2, Fig. 14) are at the right in front of the machine, just above the keyboard. By depressing the left-hand key the color on the upper half of the Ribbon may be used. By depressing the right-hand key the color on the lower half of the ribbon is ready for use.

*Changing Ribbons.*

Place the Carriage in a central position, pull down the Shift Key Lock (Plate 2, Fig. 11) and depress the Right Shift Key. Wind the Ribbon all on one Spool, remove the Spools from the Cups and the Ribbon from the Ribbon Guide (Plate 5, Fig. 4). Detach the Ribbon from the empty spool and attach the end of the new Ribbon by the hook (Plate 7, Fig. 1), with which all Ribbons purchased from the Underwood Typewriter Company are equipped, to the empty Spool. Wind the Ribbon around the empty Spool a few times, until the eyelet (Plate 7, Fig. 2) reaches the hub, being sure that the Ribbon feeds to the front on both Spools, as shown in Plate 6.

Place the Spools in the Cups, pass the Ribbon through the slots in the Cups, in front of the rollers and through the reversing levers (Plate 5, Figs. 5 and 6) being careful, of course, that the eyelet is inside the Cup and reversing lever as shown in Plate 5, Fig. 7. This is done by taking hold of the handles (Plate 5, Figs. 8 and 9) extending from the sides of the Ribbon Cups, and drawing them towards you, thus



PLATE 6



throwing the rollers and automatic reversing levers into such a position that the Ribbon can be inserted easily. Care must be taken when placing the Spools in the Cups to see that the pins in the bottom of the Cups enter the holes in the Ribbon Spool hubs.

Place the Ribbon back of the Ribbon Guide (Plate 5, Fig. 4) then bring it forward in front of the pins in the Ribbon Guide, making a small loop in the Ribbon and pushing it down in the opening in each side of the Guide (Plate 5, Figs. 10 and 11).

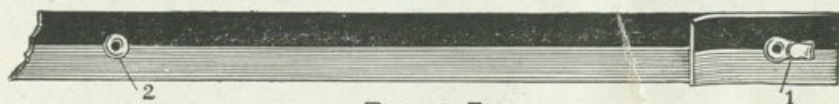

PLATE 7

### *New Ribbons.*

Good work can only be secured by using the very best Ribbons, evenly inked and of the proper texture. The famous "Underwood Ribbons," manufactured by John Underwood & Co., New York, for all makes of machines, will give the most satisfactory results. The quality of the Underwood Ribbons, manufactured expressly for use on the Underwood Typewriter, is guaranteed by the manufacturers of the machine. They are supplied on regular Ribbon Spools which are also made expressly for the machine and fit accurately.

The Underwood Ribbons are sold by all local dealers in the Underwood Typewriter.

### *The Tabular Key.*

The Tabular Key (Plate 2, Fig. 15) is not operated in the same manner as the other keys. In other words it should be pressed down and held firmly until the Carriage has reached the Tabular Stop, when it can be released.

The movement of the Carriage is governed by an Automatic Friction Brake in the form of a leather cushion with which the Tabular Frame (Plate 3, Figs. 5 and 6) comes in contact when the Tabular Key is depressed. It will be ob-

served, therefore, that the harder the Tabular Key is depressed the slower will be the action of the Carriage.

### *The Tabular Stops.*

The Tabular Stops (Plate 3, Fig. 7) are at the back of the machine, on the rod of the Tabular Frame. The Scale of the Tabular Frame (Plate 3, Fig. 8) is graduated to correspond with the Front Scale (Plate 1, Fig. 4, and Plate 2, Fig. 16) of the machine, and when the Tabular Stops are set at a given point on the Tabular Scale the Carriage will stop at a corresponding position on the Front Scale.

For example, if it is desired to stop the Carriage at 45 on the Front Scale set one of the Tabular Stops at 45 on the Tabular Scale and depress the Tabular Key. These Stops can be set at any desired point by pulling them back out of the teeth of the Tabular Rack, when they can be pushed freely in either direction and reset at the position desired. Be sure that the Stop and Rack mesh tightly.

If it is not desired to use these Stops throw them back out of the teeth of the Tabular Rack.

In adjusting these Stops the beginner should hold the Carriage with one hand to prevent it jumping if the rack is pressed in.

For Billing or special form work the machine can be equipped with any number of Stops desired.

### *Back Space Key.*

The Back Space Key is at the upper left-hand side of the keyboard (Plate 1, Fig. 18, and Plate 2, Fig. 17).

By depressing this key the Carriage is moved to the right, or back, one space.

### *The Centering Scale, Plate 8.*

The Centering Scale is designed for centering Headings, etc., on the paper. For example, to center the words

UNDERWOOD TYPEWRITER

proceed as follows:

Insert the paper as near the center of the Cylinder as possible, with the Carriage Pointer or Scale Indicator at zero (0). Space, by means of the Space Bar, once for each character and space in the words of the Heading, after which operation the Indicator will be at 30, in the example, on the



Centering or lower (red) Scale; then move the Carriage until the Indicator is at 30 on the regular or upper (white) Scale, when the writing point is in position to place the Heading in the center of the page.

The foregoing illustration is for Pica type, or an 80 Scale Machine. When using Elite type or a 96 Scale Machine, the general process is the same, but the figures will differ. After spacing out the words as described above, the Indicator will stand at 20 on the upper (white) Scale and 38 on the lower (red) Scale. The Indicator should then be set at 38 on the upper (white) Scale, which will be the position for writing the Heading in the center of the page.

Should the number of spaces in a Heading end with the Indicator between spaces on the lower (red) Scale, space once more, and move the carriage until the Indicator is at the corresponding number on the upper (white) Scale.



PLATE 8—CENTERING SCALE

#### *Making Corrections.*

If a letter is struck too lightly or omitted and the omission is discovered before the paper is removed, return the paper to the printing point with the blank space behind the slot in the Type Guide, and insert the character.

If it is necessary to make an erasure turn the paper forward a few spaces by means of the Cylinder Knobs, thus bringing the line in a more convenient position on top of the Cylinder. After the erasure has been made brush or blow the erasings back off the machine. Return the paper to the proper position and correct as above.

If the correction is made after the paper has been removed from the machine re-insert it, raise the Cylinder Ratchet Release and roll the paper upward by means of the Cylinder Knobs until the line of writing appears just above the Cylinder Scale. Depress the Paper Release Key and adjust the paper until it is parallel with the Cylinder Scale and the centers of the printed letters come just above the lines on the Cylinder Scale, when the correction can be made accurately. Of course, care must be taken to return the Paper Release Key to its normal position.

*The Envelope Guide.*

The Envelope Guide (Plate 3, Fig. 9) is just back of the Scale Indicator. When its use is desired simply turn it around to the Cylinder.

In inserting cards or envelopes when using the Envelope Guide care should be taken to direct them properly behind the Guide. We have devices and attachments to meet any requirement for card writing.

Although the Envelope Guide does not obstruct the view of the work it is advisable to turn it back out of the way when cards or envelopes are not being used. It may be turned in either direction.

*Varying Widths of Paper.*

The Carriage of the Nos. 4 and 5 models will take paper 10 1-2 inches in width, while the various lengths of the No. 3 Carriage will accommodate paper 12, 14, 16, 18, 20 and 26 inches wide.

If a narrow or note sized paper is used move the Paper Fingers (Plate 2, Figs. 18 and 19, Plate 3, Figs. 10 and 11) to either edge of the paper, adjust the marginal stops (Plate 1, Figs. 2 and 3, Plate 2, Figs. 1 and 2) and proceed as if writing on regular sized paper.

*Stencil Cutting.*

To cut a Duplicator Stencil the type should first be thoroughly cleaned. The Ribbon must be thrown out of commission. To do this the small lever (Plate 2, Fig. 20) should be pushed to the left, thus disengaging the Ribbon Throw, when the type will strike the Stencil Paper direct. To resume writing with the Ribbon throw this lever back to the right.

(Full and complete directions for making Stencils accompany each Duplicator outfit or package of Underwood Stencil Paper.)

*Cleaning Machine.*

The Typewriter should be thoroughly cleaned daily be-



fore beginning operation. Especial care should be given to keeping the back rod clean and the Carriage Shift Rail underneath the center of the Carriage, and on which it rides.

Brush the dust off, clean the rods and type thoroughly.

To clean the machine draw the Carriage to the left and brush dust from right side of machine back of type-bar connections. Repeat the same operation on the other side.

The enamel and nicked parts should be polished occasionally with chamois skin.

When not in use keep the machine covered.

#### *Cleaning the Type.*

The Type are very accessible and should be kept clean at all times. Use a stiff brush such as is furnished with the machine, always brushing toward you.

#### *Oiling.*

After cleaning the machine thoroughly such parts as require it should be oiled.

Use only the very best oil, preferably the Underwood Oil furnished by this Company.

Wipe off all superfluous oil except at the exact spot where friction is liable.

Superfluous oil catches dust and such accumulations retard the free action of the machine.

The back rod especially should be kept moist with oil.

#### *What Not to Do.*

In the care of your machine what not to do is quite as important as what to do.

Do not take the machine apart.

Do not remove the carriage.

Do not oil the type bar bearings.

Do not loosen the screws.

Do not change the adjustments.

Do not allow others to do these "Do Nots."

